



TRUST. WELL EARNED.

ECLIPSE 12kV Fixed Pattern Indoor Metalclad Vacuum Switchgear

The Eclipse is designed to provide a lifetime of unrivalled service, bringing together one of the most advanced operating mechanisms available on the market today, the award-winning magnetic actuator technology.

Key Features

- Superior technology with minimal maintenance
- The fixed pattern design has the simplicity of air insulation and, with the low parts count (the total parts count has been reduced by a factor of x20 and the number of moving parts by a factor of x50), is more compact (500mm wide) than equivalent rated GIS equipment
- The Eclipse boasts of superior operator safety with a fully interlocked disconnector selector mechanism, animated front panel mimic and a front access cable test facility, eliminating the need for any intrusive access to high-voltage compartments
- The Eclipse is certified to IEC62271 and available as a pre-engineered solution in ratings up to 25kA, 2000A. Alternatively, it can be fully engineered to meet exact customers needs
- Environmentally friendly vacuum interrupters
- Internal arc containment
- Voltage Presence Indication System (VPIS) is fitted as standard to all panels (circuit)
- Award-winning magnetic actuator technology powered from substation battery via contactors
- Trip circuit supervision, self diagnostics & position indication contacts included as standard
- Customer's choice of protection

Ratings

Rated Normal Current

630/1250/2000A

Rated Voltage

12 kV

Rated Frequency

50 Hz

Rated BIL

75/95 kV pk

Rated Power Frequency Withstand

28/38 kV 1min

Rated Short-Time Withstand Current

20/25 kArms 3secs

Rated Peak Making Current

50/62.5 kA

Internal Arc Compliance

20 kA 1sec

Rated Short Circuit Breaking Current

20/25kA

Degree of Protection

IP4X

Single Capacitor Bank Breaking Current

400/1250A

Circuit Breaker Classification

E2, S2, C2

Auxiliary Operating Supply

125/110/48/30 V dc

Busbars Normal Current

1250, 2000A

Typical Weight

500 - 650kg

Ambient Air Temperature

-5 °C to +40 °C

Relative Humidity

<95%

Altitude

<1000m

Mechanical Endurance

M2, 10,000 operations



Dimensions (mm)

Dimensions for a standard Eclipse feeder/incomer panel;

(a) 1162 **(b)** 2160 **(c)** 500

Dimensions for a standard Bus-section panel;

(a) 1162 **(b)** 2160 **(c)** 1000

Dimensions for a Busbar earthing switch;

(c) 325

Dimensions for a single panel with Busbar VT;

(b) 2500

Dimensions for top entry cable;

One cable per phase - **(a)** 1482

Three cables per phase - **(a)** 1812

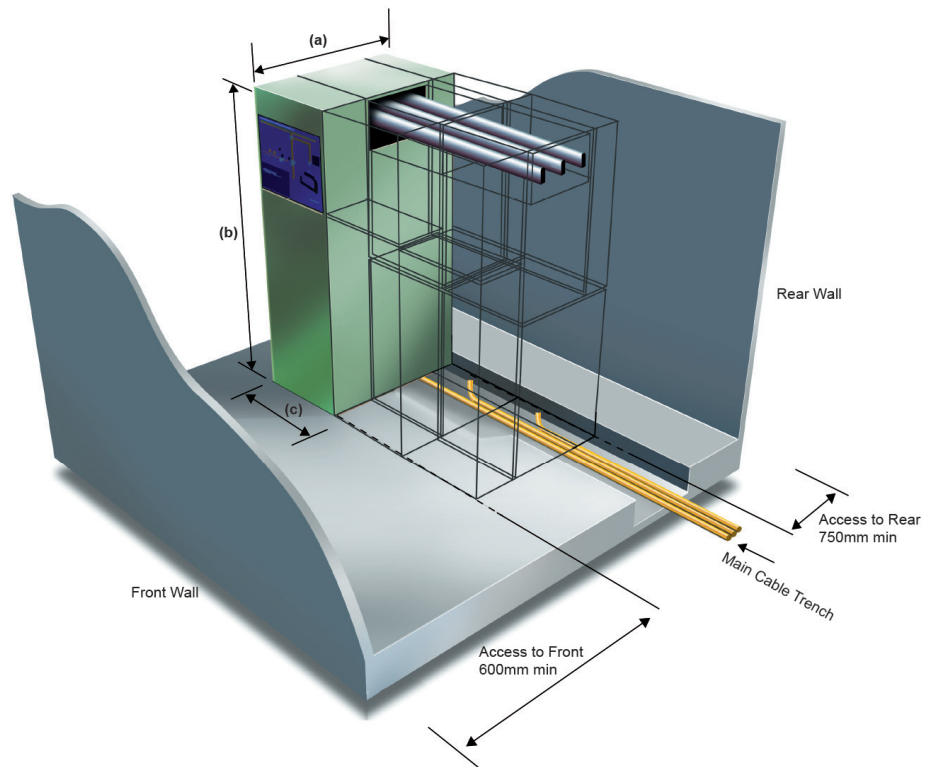

Eclipse Engineering Detail

- 1 Sleeved busbars constructed from hard drawn, high conductivity copper, and vermin proof covered joints, with normal current ratings up to 2000A. The busbar arrangement permits future expansion, at either end of the switchboard.
- 2 Fully interlocked, manually operated 3-position disconnecter including circuit earth and front panel cable test access. The disconnecter can be secured and padlocked in all three positions: 'on', 'off' and 'earth on/test', with its status indicated by animated front panel mimics.
- 3 A single moulding supports the three phase vacuum interrupter assembly, magnetic actuator mechanism and one-piece drive beam.
- 4 The patented single coil magnetic actuator mechanism is based on a solenoid plunger, held in the tripped or closed position by permanent magnets.
- 5 Three phase cast resin voltage transformer, with manually operated off-load disconnecter on the primary circuit.
- 6 Generous CT accommodation enables complex protection schemes to be catered for in a single panel, whilst still allowing for a metering provision. The CT designs are rated in keeping with the short time withstand level of the equipment and comply with IEC 60044-1.

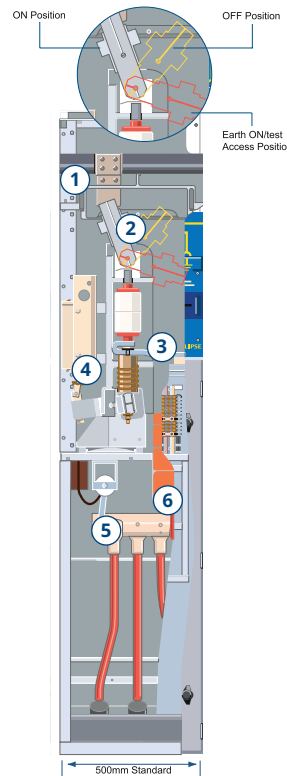

Feeder/Incomer Panel

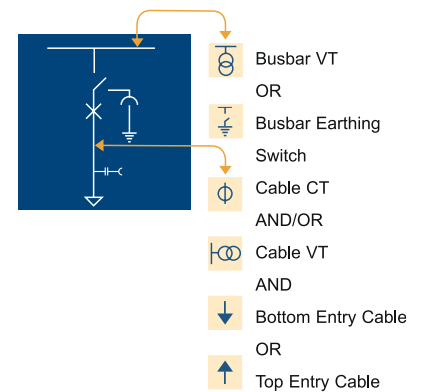

Busbar Coupler Panel

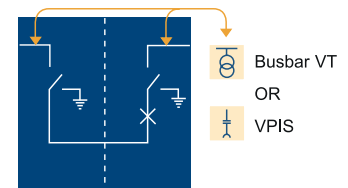

Busbar Earthing Switch

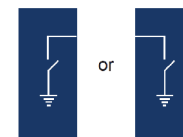

Standards

- IEC 62271 Series of Standards
- ENA Notice of Conformity No. 1024

Patents

- GB2289374B
- EP 0 909 453 B1



BRUSH Switchgear

UK: Unit 4, Hawtin Park, Gellihaf, Blackwood, South Wales, NP12 2XH, United Kingdom

T: +44 (0) 1495 223 001

E: sales@brushswitchgear.com

Australia: Unit 6, 256 Leitchs Road, Brendale, QLD. 4500, Australia

T: +61 (7) 3888 2333

www.brush.eu